

NOTES: UNLESS OTHERWISE SPECIFIED

- CONSTRUCTION:
HOUSING & PLUNGER: MOLDED NYLON. AVAILABLE IN TEN COLORS.
CONTACT BLADE: NICKEL SILVER ALLOY.
SPRING: STAINLESS STEEL.
- PERFORMANCE:
MAXIMUM CURRENT: 10.9 AMPS WITH A 76° TEMPERATURE RISE.
MAXIMUM VOLTAGE: 2.4 KV
MAXIMUM TEMPERATURE: 200°F (93°C)
- FEATURES:
HOOK PIERCES WIRE UP TO $\varnothing 0.140$ [$\varnothing 3.56$].
FIELD SERVICEABLE.

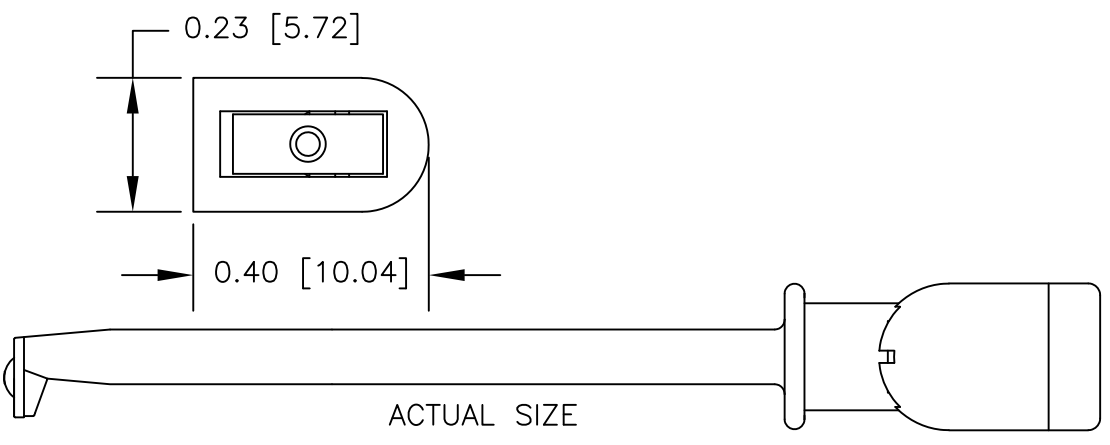
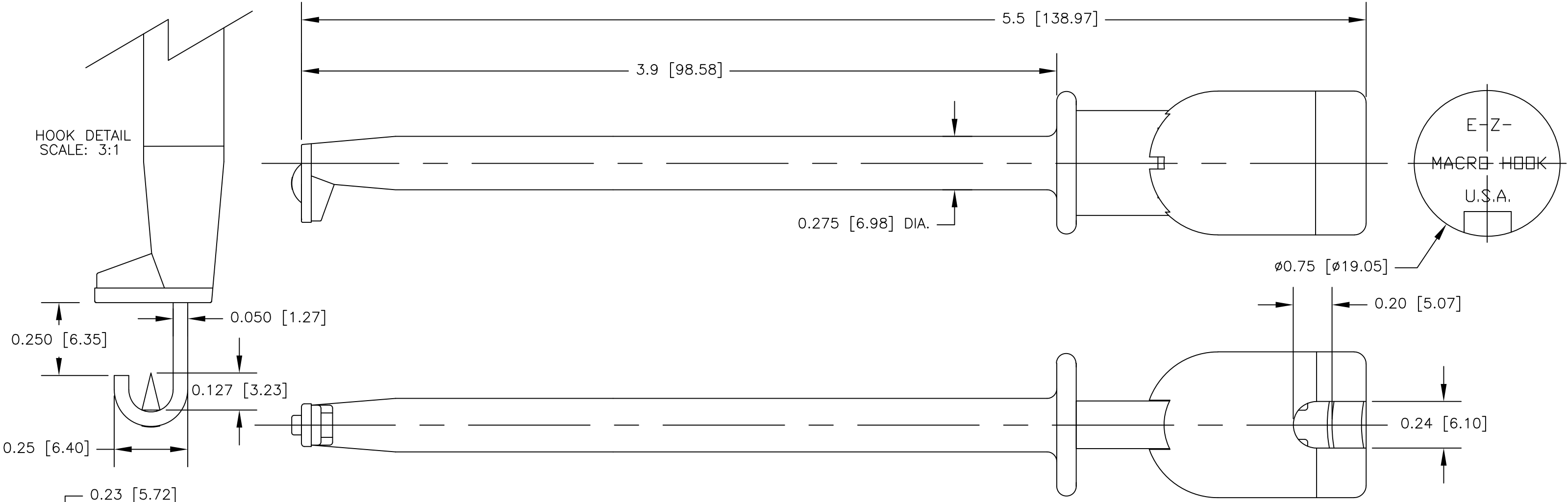
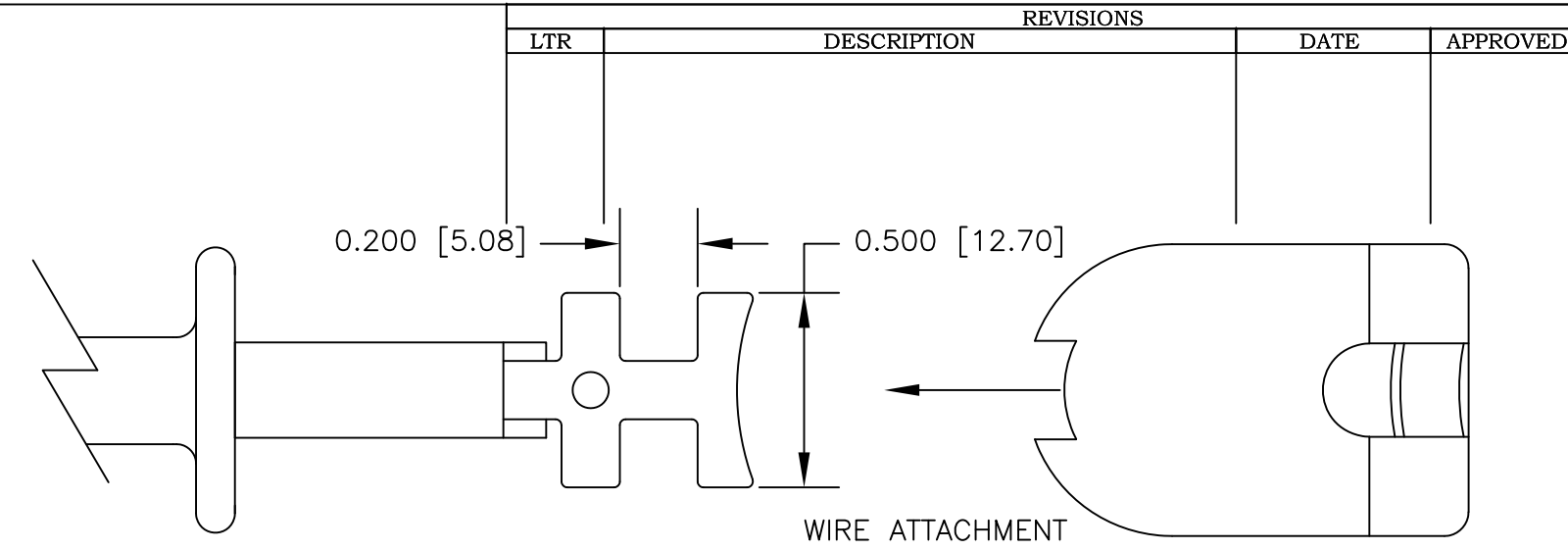

		UNLESS OTHERWISE SPECIFIED DIMENSIONS ARE IN INCHES TOLERANCES ARE: FRACTIONS DECIMALS ANGLES ± .XX ± ± .XXX ±	CONTRACT NO.		E-Z-HOOK DIVISION OF TEKTEST INC. ARCADIA, CA 91006 U.S.A.
			APPROVALS	DATE	
		MATERIAL SEE NOTE.	DRAWN R.L.	6/09	DESCRIPTION E-Z-MACRO HOOK. INSULATION-PIERCING, LONG
		FINISH SEE NOTE.	APPROVED BY		SIZE B
NEXT ASSY	USED ON				CODE IDENT NO. 08505
APPLICATION		DO NOT SCALE DRAWING			DRAWING NO. XJL
					REV.
				SCALE 2:1	SHEET 1 OF 1