

NOTES: UNLESS OTHERWISE SPECIFIED

- CONSTRUCTION:  
SLIDE: MOLDED NYLON. AVAILABLE IN TEN COLORS.  
CONTACT BLADE: NICKEL SILVER  
SPRING: STAINLESS STEEL
- PERFORMANCE:  
MAXIMUM CURRENT: 5 AMPS  
MAXIMUM VOLTAGE: 0 V  
MAXIMUM TEMPERATURE: 200°F (93°C)
- INSTALLATION TOOL P/N T-20

LTR	DESCRIPTION	DATE	APPROVEI

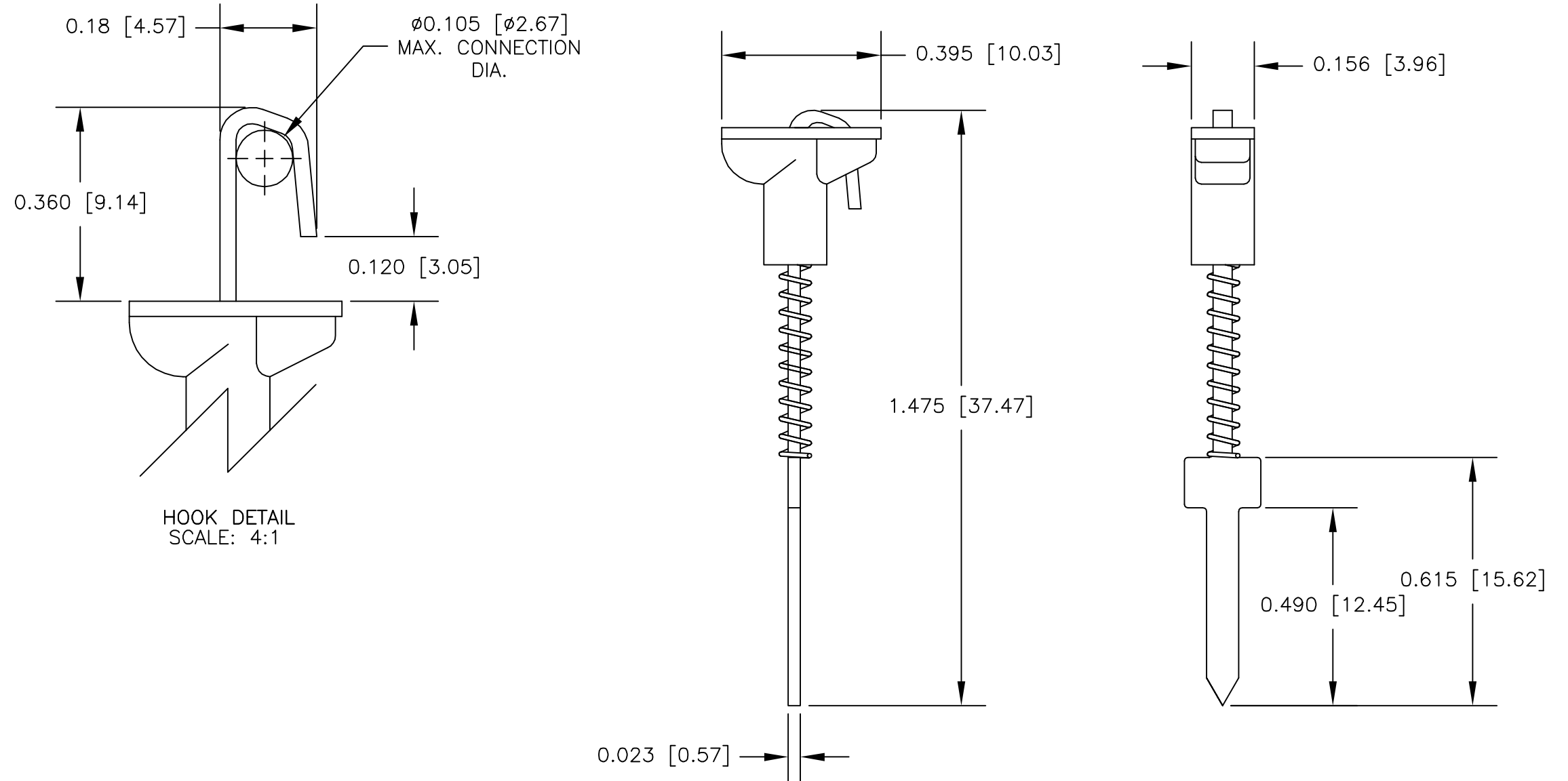

ACTUAL SIZE

		UNLESS OTHERWISE SPECIFIED DIMENSIONS ARE IN INCHES TOLERANCES ARE: FRACTIONS DECIMALS ANGLES ± .XX ± ± .XXX ±	CONTRACT NO.		<b>E-Z-HOOK</b> DIVISION OF TEKTEST INC. ARCADIA, CA 91006 U.S.A.			
			APPROVALS	DATE				
		MATERIAL SEE NOTE.	DRAWN	R.L.	7/06			
			APPROVED BY					
NEXT ASSY	USED ON	FINISH SEE NOTE.	DESCRIPTION		E-Z-NAIL CLIP MULTIPLE WIRE TEST TERMINAL			
APPLICATION			DO NOT SCALE DRAWING			SIZE	CODE IDENT NO.	DRAWING NO.
					<b>B</b>	<b>08505</b>	<b>83-8</b>	
					SCALE	3:1	SHEET 1 OF 1	