

NOTE: UNLESS OTHERWISE SPECIFIED

- 1 FOOT, NAIL CLIP P/N 042  
MATERIAL; MOLDED NYLON.
- 2 CONTACT BLADE P/N 045  
MATERIAL; NICKEL SILVER  
ALLOY 770 EX HARD.
- 3 SPRING P/N 051  
MATERIAL, STAINLESS STEEL  
PASSIVATED.
- 4 ITEM IS AVAILABLE IN TEN  
COLORS.
- 5 8-32 STUD P/N 0325  
MATERIAL; STEEL, PLATED
- 6 NUTS.HEX P/N 0316  
MATERIAL; STEEL, ZINC PLATED

ZONE	LTR		DATE	APPROVED

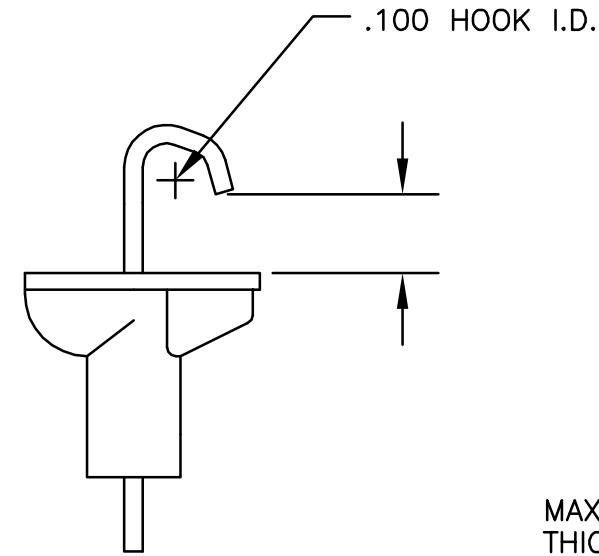

DETAIL 3X FULL SIZE

MAX PANEL THICKNESS.

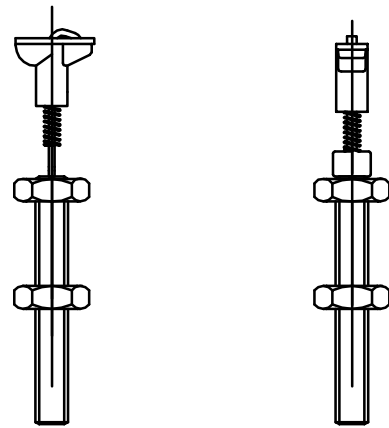
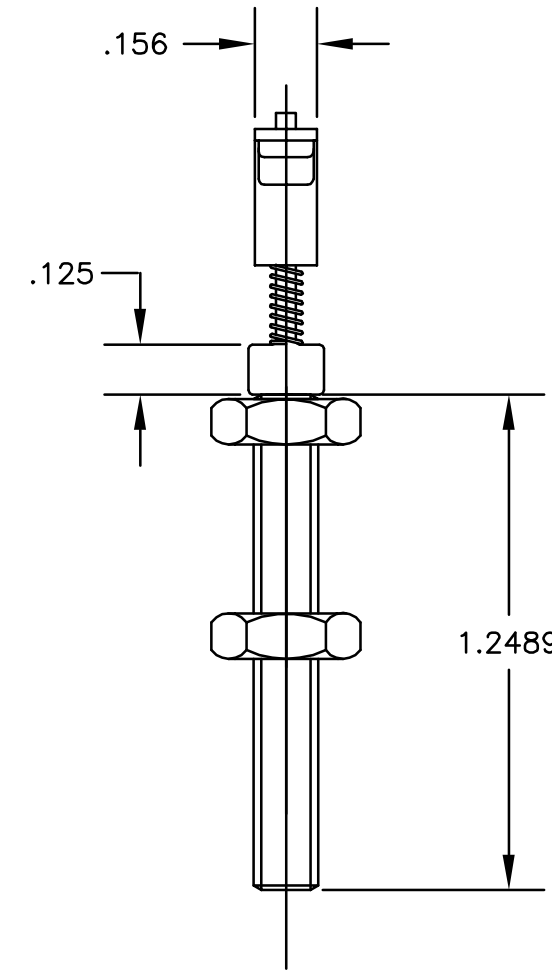
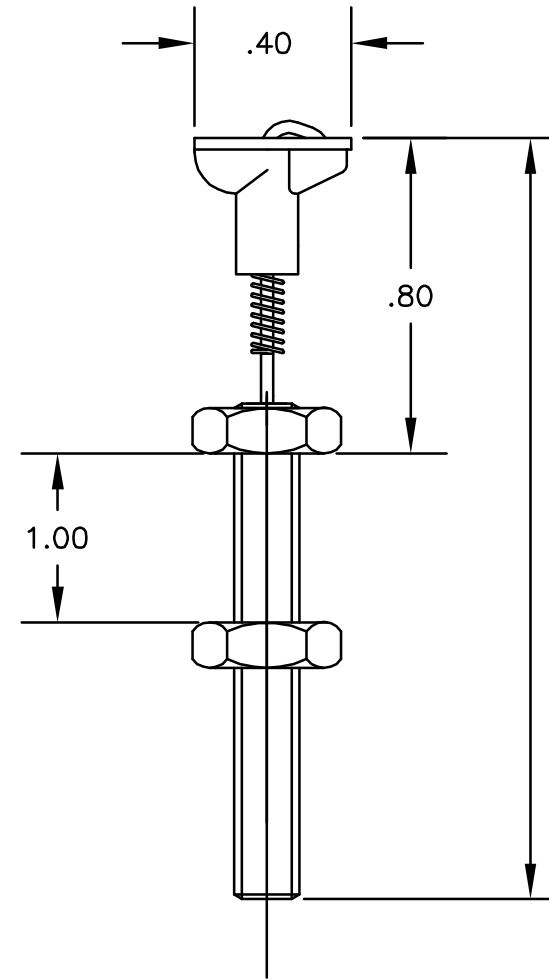

ACTUAL SIZE

		UNLESS OTHERWISE SPECIFIED DIMENSIONS ARE IN INCHES TOLERANCES ARE: FRACTIONS DECIMALS ANGLES ± .XX ± ± ± .XXX ±	CONTRACT NO.		E-Z-HOOK ARCADIA, CALIF 91006	
		MATERIAL	APPROVALS	DATE	TERMINAL CLIP ON THREADED POST	
		SEE NOTE	DRAWN S.B.W.	9/91		
		FINISH	CHECKED			
		SEE NOTE			SIZE	CODE IDENT NO.
NEXT ASSY	USED ON				B	08505
APPLICATION		DO NOT SCALE DRAWING			DRAWING NO.	8107-8 (COLOR)
					SCALE 2X	SHEET 1 OF 1