

NOTES: UNLESS OTHERWISE SPECIFIED

1. CONSTRUCTION:
 HOUSING: MOLDED NYLON. AVAILABLE IN TEN COLORS
 CONTACT: NICKEL PLATED STEEL & BRASS
 SPRING: STAINLESS STEEL
 STUD & NUT: ZINC PLATED STEEL

2. PERFORMANCE:
 MAXIMUM CURRENT: 1 AMPS
 MAXIMUM VOLTAGE: 0 V
 MAXIMUM TEMPERATURE: 200°F (93°C)

REVISIONS			
LTR	DESCRIPTION	DATE	APPROVED

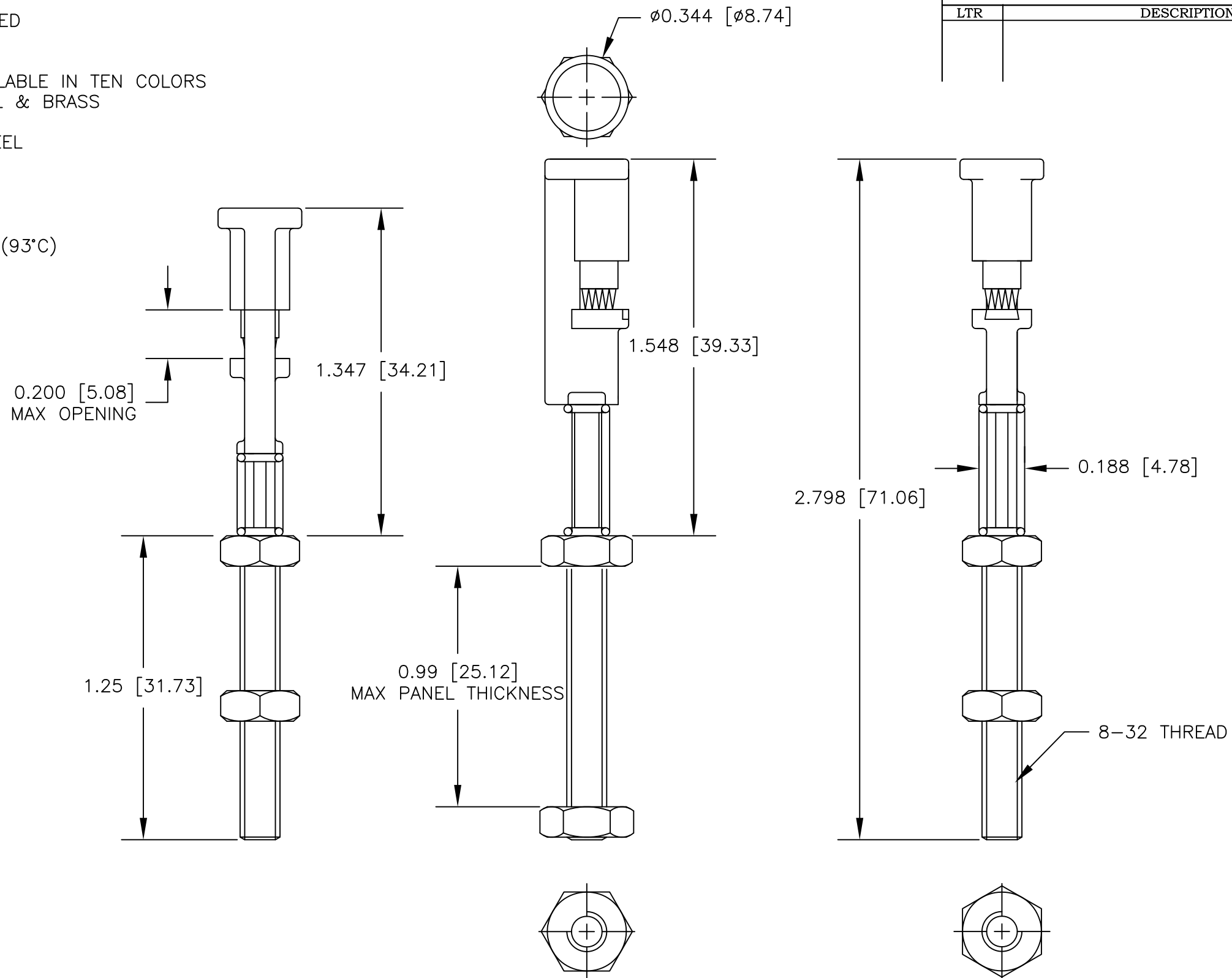

		UNLESS OTHERWISE SPECIFIED DIMENSIONS ARE IN INCHES TOLERANCES ARE: FRACTIONS DECIMALS ANGLES ± .XX ± ± .XXX ±	CONTRACT NO.		E-Z-HOOK DIVISION OF TEKTEST INC. ARCADIA, CA 91006 U.S.A.
			APPROVALS	DATE	
		MATERIAL SEE NOTE.	DRAWN	S.B.W. 3/13	DESCRIPTION INSULATION PIERCING HARNESS BOARD CONN
			APPROVED BY		
NEXT ASSY	USED ON	FINISH SEE NOTE.			SIZE B
APPLICATION		DO NOT SCALE DRAWING			CODE IDENT NO. 08505
					DRAWING NO. 8507-8
					REV.
					SCALE 1:1
					SHEET 1 OF 1