

NOTES: UNLESS OTHERWISE SPECIFIED

1. CONSTRUCTION:  
 HOUSING: MOLDED NYLON. AVAILABLE IN TEN COLORS  
 CONTACT: NICKEL PLATED STEEL & BRASS  
 SPRING: STAINLESS STEEL  
 STUD: ZINC PLATED STEEL

2. PERFORMANCE:  
 MAXIMUM CURRENT: 1 AMPS  
 MAXIMUM VOLTAGE: 0 V  
 MAXIMUM TEMPERATURE: 200°F (93°C)

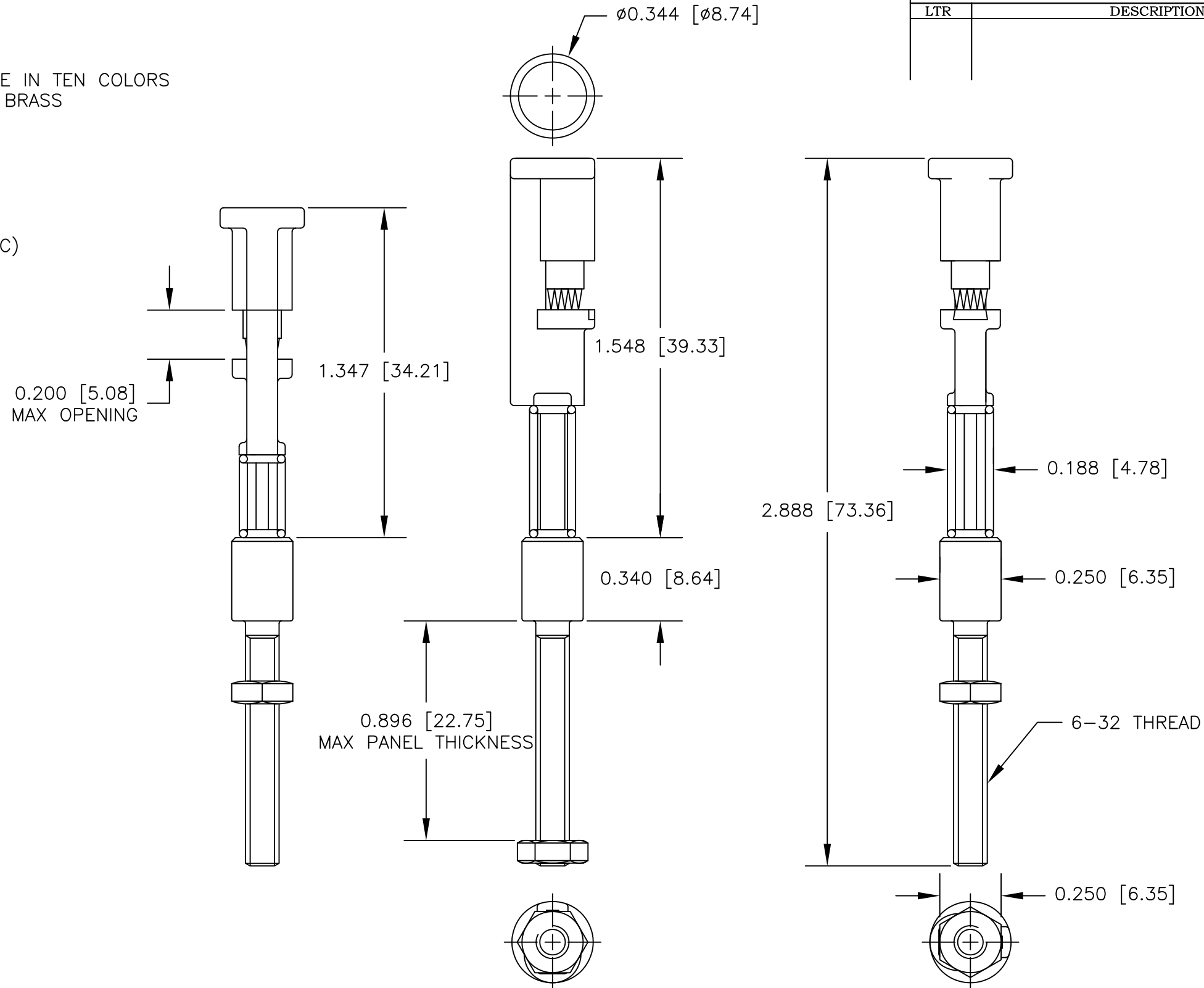

| REVISIONS |             | DATE | APPROVED |
|-----------|-------------|------|----------|
| LTR       | DESCRIPTION |      |          |

|             |         |   |  |              |        |  |   |             |              |
|-------------|---------|---|--|--------------|--------|--|---|-------------|--------------|
|             |         | UNLESS OTHERWISE SPECIFIED<br>DIMENSIONS ARE IN INCHES<br>TOLERANCES ARE:<br>FRACTIONS DECIMALS ANGLES<br>± .XX ± ±<br>.XXX ± |  | CONTRACT NO. |        | <b>E-Z-HOOK</b> DIVISION OF TEKTEST INC.<br>ARCADIA, CA 91006 U.S.A. |   |             |              |
|             |         | MATERIAL<br>SEE NOTE.   |  | APPROVALS    | DATE   |  |   |             |              |
|             |         | FINISH<br>SEE NOTE.   |  | DRAWN        | S.B.W. | 3/13   | DESCRIPTION                               |             |              |
| NEXT ASSY   | USED ON |   |  | APPROVED BY  |        |  | INSULATION PIERCING<br>HARNESS BOARD CONN |             |              |
| APPLICATION |         | DO NOT SCALE DRAWING  |  |              |        | SIZE   | CODE IDENT NO.                            | DRAWING NO. | REV.         |
|             |         |   |  |              |        | <b>B</b>   | <b>08505</b>                              | 8507-6      |              |
|             |         |   |  |              |        | SCALE  | 1:1                                       |             | SHEET 1 OF 1 |