

NOTES: UNLESS OTHERWISE SPECIFIED

1. CONSTRUCTION:  
 HOUSING: MOLDED NYLON. AVAILABLE IN TEN COLORS  
 CONTACT: NICKEL PLATED STEEL & BRASS  
 SPRING: STAINLESS STEEL  
 STUD & NUT: ZINC PLATED STEEL

2. PERFORMANCE:  
 MAXIMUM CURRENT: 1 AMPS  
 MAXIMUM VOLTAGE: 0 V  
 MAXIMUM TEMPERATURE: 200°F (93°C)

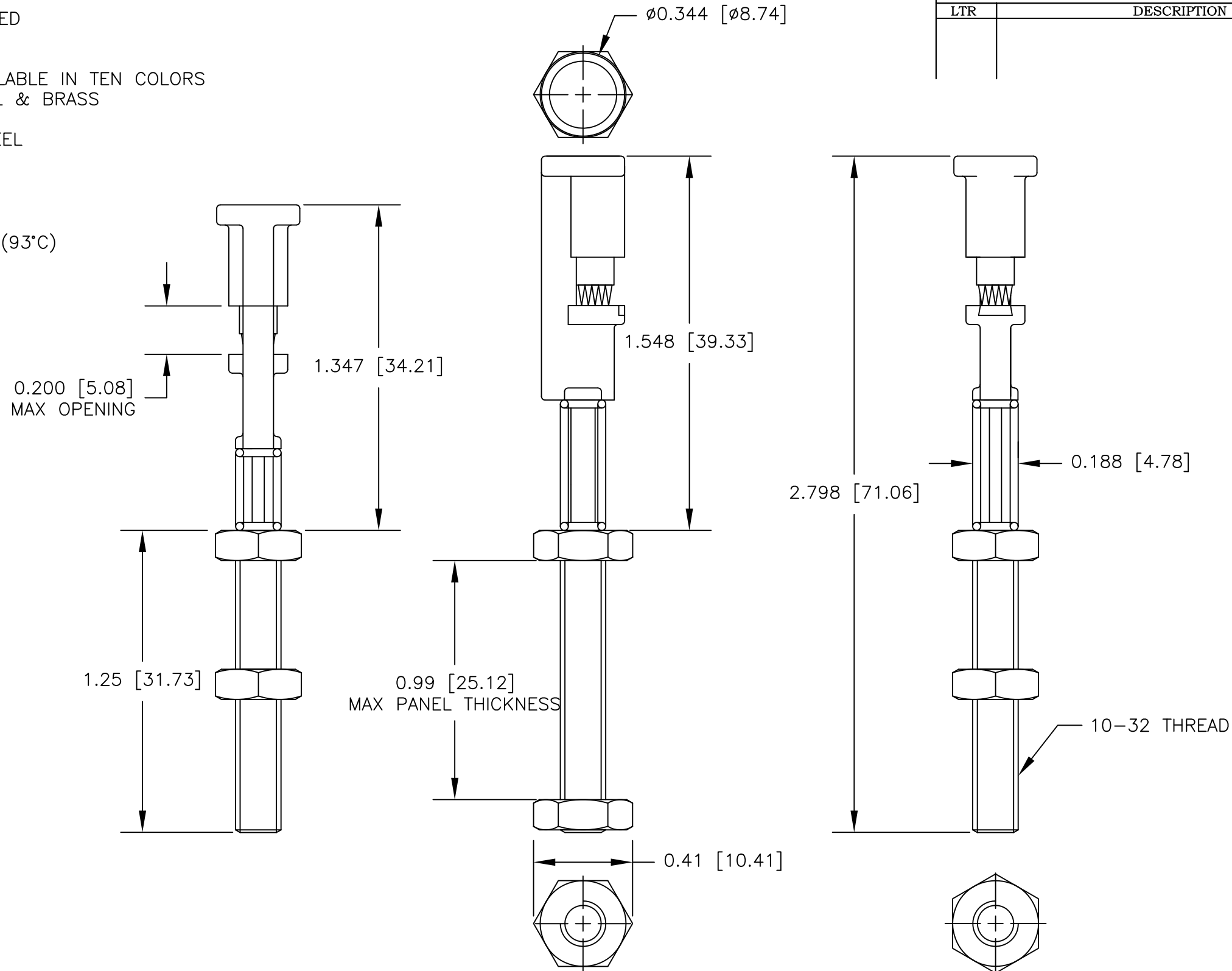

LTR		REVISIONS		DATE	APPROVED
DESCRIPTION					

		UNLESS OTHERWISE SPECIFIED DIMENSIONS ARE IN INCHES TOLERANCES ARE: FRACTIONS DECIMALS ANGLES ± .XX ± ± .XXX ±		CONTRACT NO.		<b>E-Z-HOOK</b> DIVISION OF TEKTEST INC. ARCADIA, CA 91006 U.S.A.	
		MATERIAL SEE NOTE.		APPROVALS	DATE		
		FINISH SEE NOTE.		DRAWN	S.B.W.	3/13	DESCRIPTION
NEXT ASSY		USED ON		APPROVED BY			INSULATION PIERCING HARNESS BOARD CONN
APPLICATION		DO NOT SCALE DRAWING					SIZE
							CODE IDENT NO.
							DRAWING NO.
							REV.
							B 08505 8507-10
							SCALE
							1:1
							SHEET 1 OF 1