

NOTES: UNLESS OTHERWISE SPECIFIED

1. P/N: 8901
 BODY & FITTINGS: NICKEL PLATED BRASS
 CONTACT: GOLD PLATED BRASS.
 DIELECTRIC: PTFE
 SPRING: NICKEL PLATED SK5
 GASKET: RED RUBBER

2. P/N: SR58BLK
 BOOT: BLK MOLDED PVC

3. P/N: Y-1000
 HOUSING: BLK MOLDED NYLON
 HARDWARE: SS SCREW, NUTS & WASHER

4. P/N: 9275BLK
 INSULATOR: BLK MOLDED PVC.
 ALLIGATOR: NICKEL PLATED STEEL.

5. P/N: XKRED
 HOUSING: RED GLASS FILLED CELCON.
 CONTACT: STAINLESS STEEL.
 SPRING: STAINLESS STEEL.

6. P/N: W-500/0
 20AWG TINNED COPPER STRANDING
 0.080 [2.03] O.D. PVC INSULATION

7. P/N: W-500/2
 20AWG TINNED COPPER STRANDING
 0.080 [2.03] O.D. PVC INSULATION

8. P/N: C-1000/0
 20AWG RG58C/U CABLE
 0.195 [4.95] O.D. PVC INSULATION

LTR	REVISIONS		DATE	APPROVED
	DESCRIPTION			

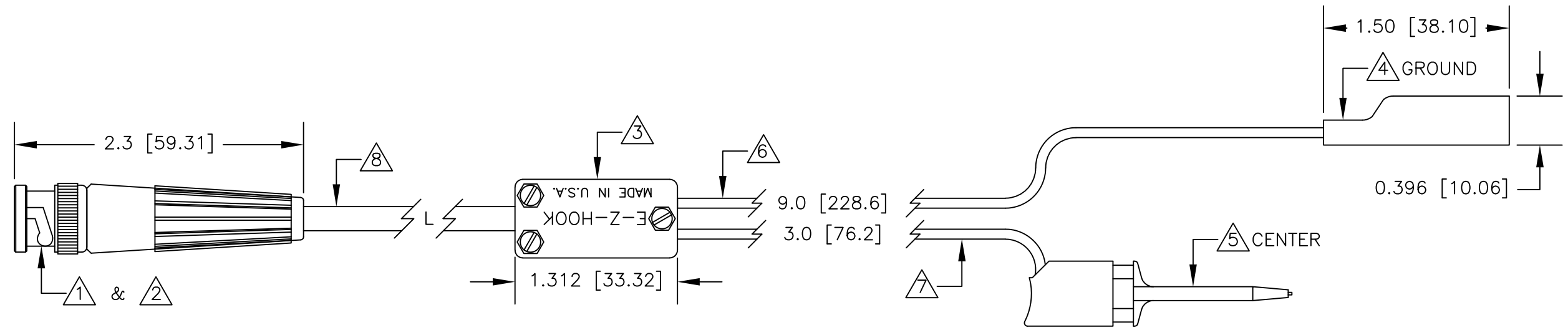
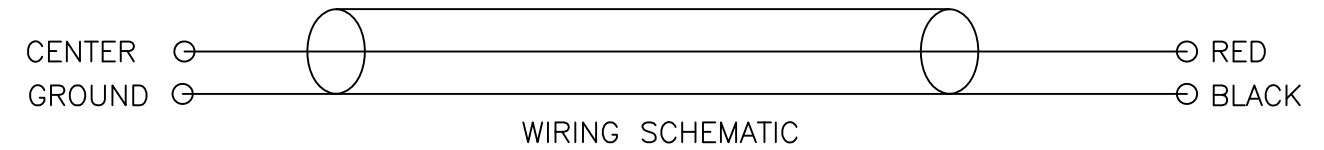

		UNLESS OTHERWISE SPECIFIED DIMENSIONS ARE IN INCHES TOLERANCES ARE: FRACTIONS DECIMALS ANGLES ± N/A .XX ± N/A ± N/A .XXX ± N/A	CONTRACT NO.		E-Z-HOOK DIVISION OF TEKTEST INC. ARCADIA, CA 91006 U.S.A.
			APPROVALS	DATE	
		MATERIAL SEE NOTE	DRAWN R.L.	8/18	DESCRIPTION BNC MALE TO 9275 GRD/ XM CTR LEADS, RG58 CABLE
		FINISH SEE NOTE	APPROVED BY		
NEXT ASSY	USED ON				SIZE CODE IDENT NO. DRAWING NO. REV.
APPLICATION		DO NOT SCALE DRAWING			B 08505 1021XK
					SCALE 1:1 SHEET 1 OF 1

THE INFORMATION CONTAINED IN THIS DOCUMENT IS PROPRIETARY TO E-Z-HOOK. THE INFORMATION IS NOT TO BE REPRODUCED WITHOUT PRIOR WRITTEN PERMISSION OF E-Z-HOOK, DIV. OF TEKTEST INC. MAXIMUM TESTED RATINGS IN A HANDS-FREE CONTROLLED ENVIRONMENT. MAXIMUM RATINGS ARE NOT TO BE USED CONCURRENTLY.