

NOTES: UNLESS OTHERWISE SPECIFIED

1. P/N: 9267-0002 & P/N: 0344  
 BODY & FITTINGS: NICKEL PLATED BRASS  
 CONTACT: GOLD PLATED BRASS.  
 DIELECTRIC: PTFE  
 SPRING: NICKEL PLATED SK5  
 SPRING: RED RUBBER  
 WASHER: COPPER, TIN, NICKEL PLATED CSR

2. P/N: 0480 & P/N: 0148/0 & P/N: 0581  
 HOUSING: BLK MOLDED DELRIN  
 CONTACT: GOLD PLATED BeCu  
 HEAT SHRINK: BLK HEAT SHRINK

3. P/N: 9259BLK  
 HOUSING: BLK MOLDED NYLON.  
 FRAME: NICKEL PLATED BRASS  
 SPRING: SILVER PLATED BeCu OR PHOSPHOR BRONZE

4. P/N: 9259RED  
 HOUSING: RED MOLDED NYLON.  
 FRAME: NICKEL PLATED BRASS  
 SPRING: SILVER PLATED BeCu OR PHOSPHOR BRONZE

5. P/N: W-500/0  
 20AWG TINNED COPPER STRANDING  
 0.080 [2.03] O.D. PVC INSULATION

6. P/N: W-500/2  
 20AWG TINNED COPPER STRANDING  
 0.080 [2.03] O.D. PVC INSULATION

LTR	REVISIONS		DATE	APPROVED
	DESCRIPTION			

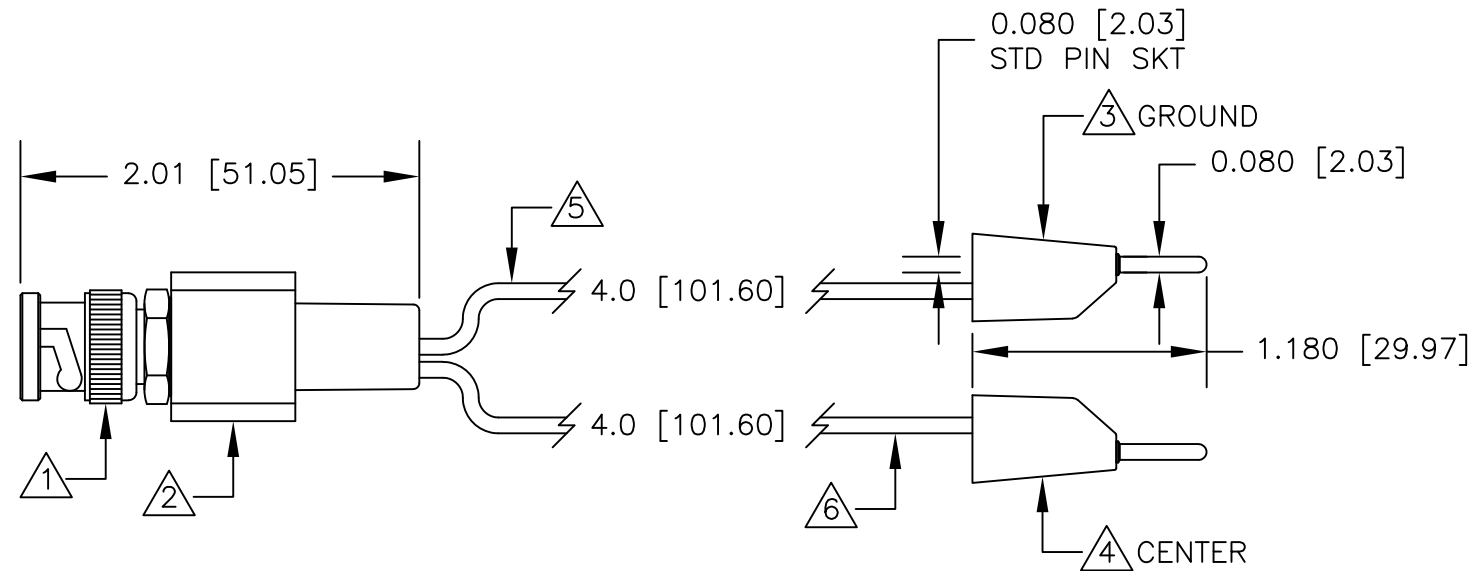
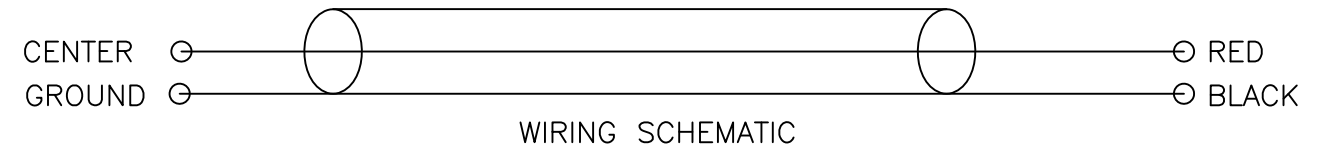

		UNLESS OTHERWISE SPECIFIED DIMENSIONS ARE IN INCHES TOLERANCES ARE: FRACTIONS DECIMALS ANGLES ± .XX ± ± .XXX ±	CONTRACT NO.		<b>E-Z-HOOK</b> DIVISION OF TEKTEST INC. ARCADIA, CA 91006 U.S.A.
			APPROVALS	DATE	
		MATERIAL SEE NOTE.	DRAWN R.L.	4/19	DESCRIPTION BNC MALE BREAKOUT TO 4" 9259 STD STK PIN PLUG LEADS
		FINISH SEE NOTE.	APPROVED BY		SIZE CODE IDENT NO. DRAWING NO. REV.
NEXT ASSY	USED ON				<b>B 08505</b> 1013
APPLICATION		DO NOT SCALE DRAWING			SCALE 1:1 SHEET 1 OF 1